

# Q-Switch Driver

## FEATURES

- ✦ Adjustable Output From -3.5kV to 0V
- ✦ Risetime  $\leq 15\text{ns}$
- ✦ Rep Rate to 100Hz

## SPECIFICATIONS

<b>Trigger Input</b>		<b>Output</b>	
Level	+5V into internal 511Ω load	Level	-3.5kV to 0V, adjustable
Pulsewidth	5μs to 1 ms	Risetime	$\leq 15\text{ns}$ into 10pF, 100MΩ
Repetition Rate	Up to 100Hz	Pulsewidth	1-5μs at 97% into 10pF, 100MΩ load
Delay	50-500 μs, adjustable by dial or external program voltage	<b>HV Output Control</b>	Multi-turn trimpot or external voltage (selectable) 4V Control yields 0V output level 8V Control yields -3.5kV output level
<b>Power</b>	100-240 VAC, 1φ, 50-440Hz	<b>Monitor</b>	Scale: 1V= -1kV output level BNC to monitor HV prior to pulse
<b>Temperature</b>	0° to 50°C	<b>Size</b>	7.07" x 5.31" x 2.25"
<b>Connectors</b>			
Trigger Input	BNC		
HV Monitor	BNC		
Ext. HV Adjust	BNC		
HV Output	SHV		

## EQUIVALENT CIRCUIT & WAVEFORM

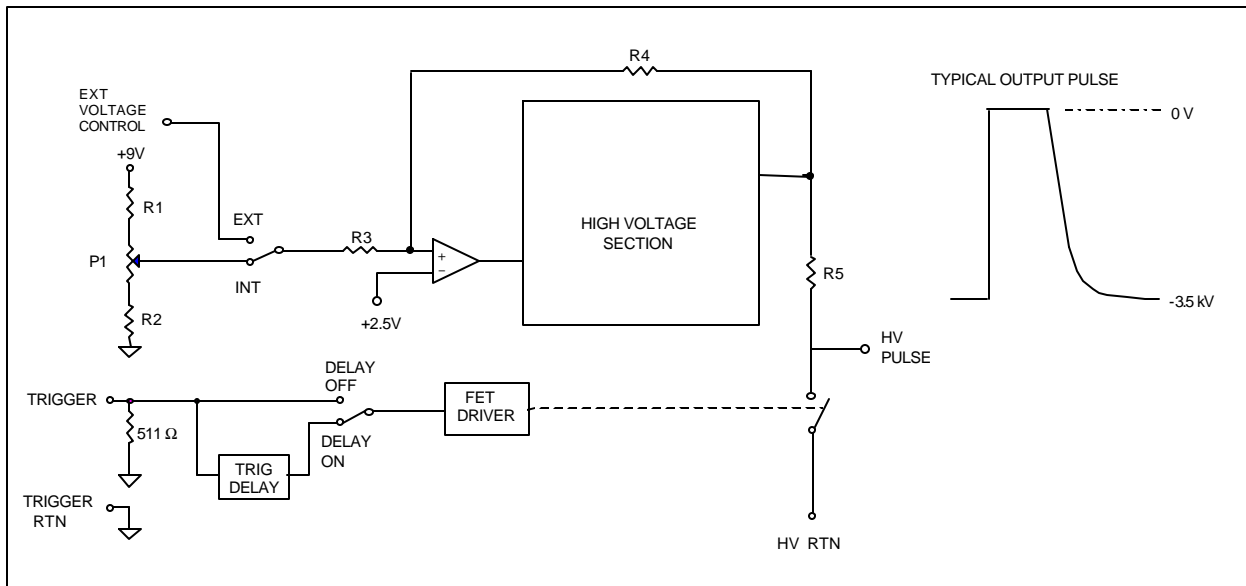

OUTLINE DRAWING – Model 2-019

